

NOTES

- Dimensions are not to be scaled.
- The contractor shall verify all dimensions, details, specifications & site conditions & shall report any error, omission and/or anomaly to the Campus Designer for approval.
- For construction purposes, the dimensions shall not be measured directly from the drawings. The drawings shall not be used for construction until they are issued for construction.
- These drawings are to be read in co-ordination with HVAC, Electrical, Plumbing drawings & all relevant sections of specifications.
- All shop drawings should be provided to the Campus Designer for approval.

GROUND FLOOR AREA = A = (4x14.40) = 57.6 SQM

FIRST FLOOR = E - (B + C + D) = (4x11.71) - (3.7x3.9) + (1.6x1.55) + (1.7x0.55) = 46.8 - (14.43+2.48+0.935) = 46.8 - 17.85 = 28.95 SQM

SECOND FLOOR = A - (B + C + D) = (4x14.4) - (3.7x3.9) + (1.6x1.55) + (1.7x0.55) = 57.6 - (14.43+2.48+0.935) = 57.6 - 17.85 = 39.75 SQM

THIRD FLOOR = A - (B + C + D) = (4x14.4) - (3.7x3.9) + (1.6x1.55) + (1.7x0.55) = 57.6 - (14.43+2.48+0.935) = 57.6 - 17.85 = 39.75 SQM

FOURTH FLOOR = A - (B + C + D) = (4x14.4) - (3.7x3.9) + (1.6x1.55) + (1.7x0.55) = 57.6 - (14.43+2.48+0.935) = 57.6 - 17.85 = 39.75 SQM

TOTAL FAR AREA PER PLOT = 205.82 SQM

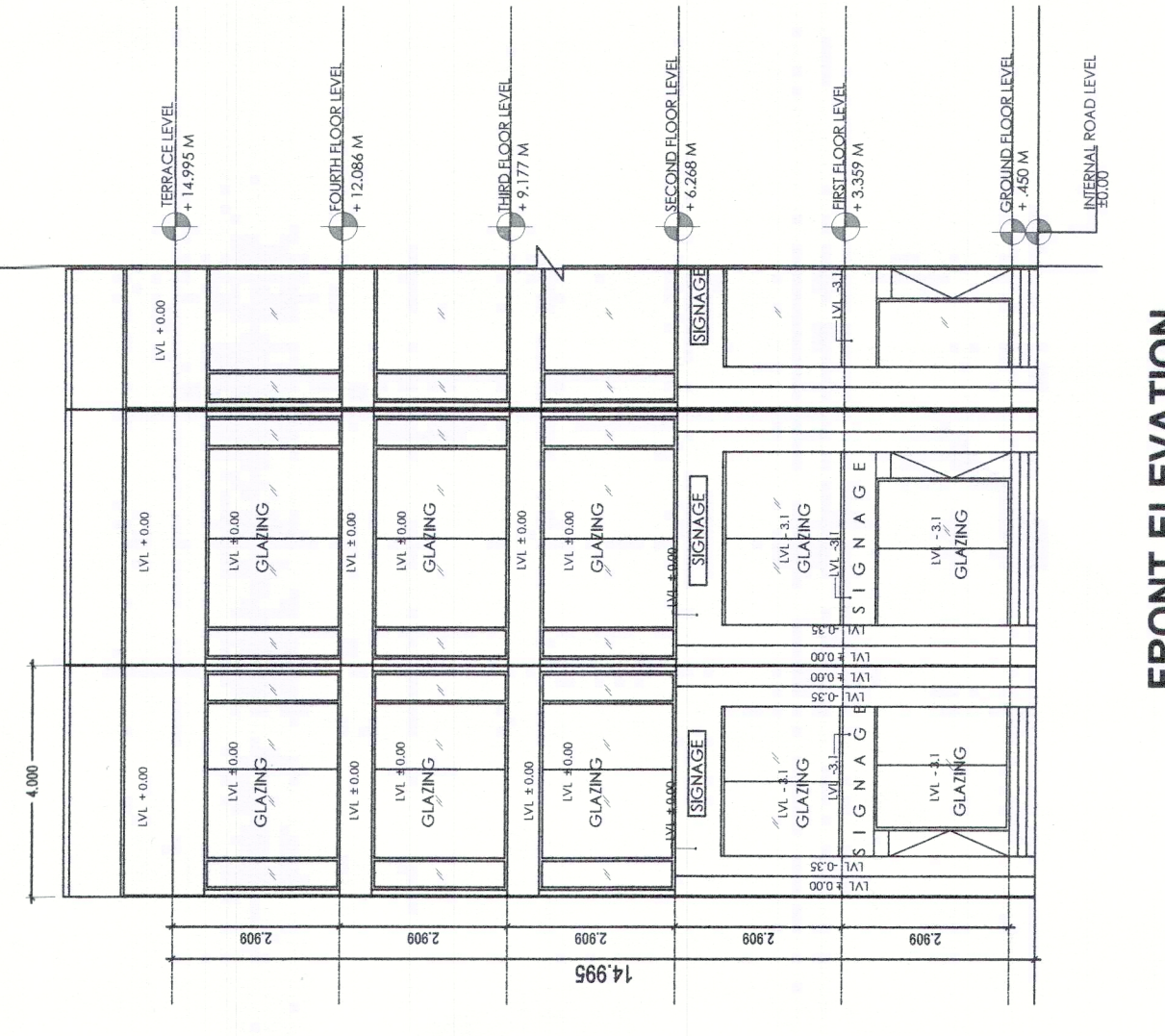
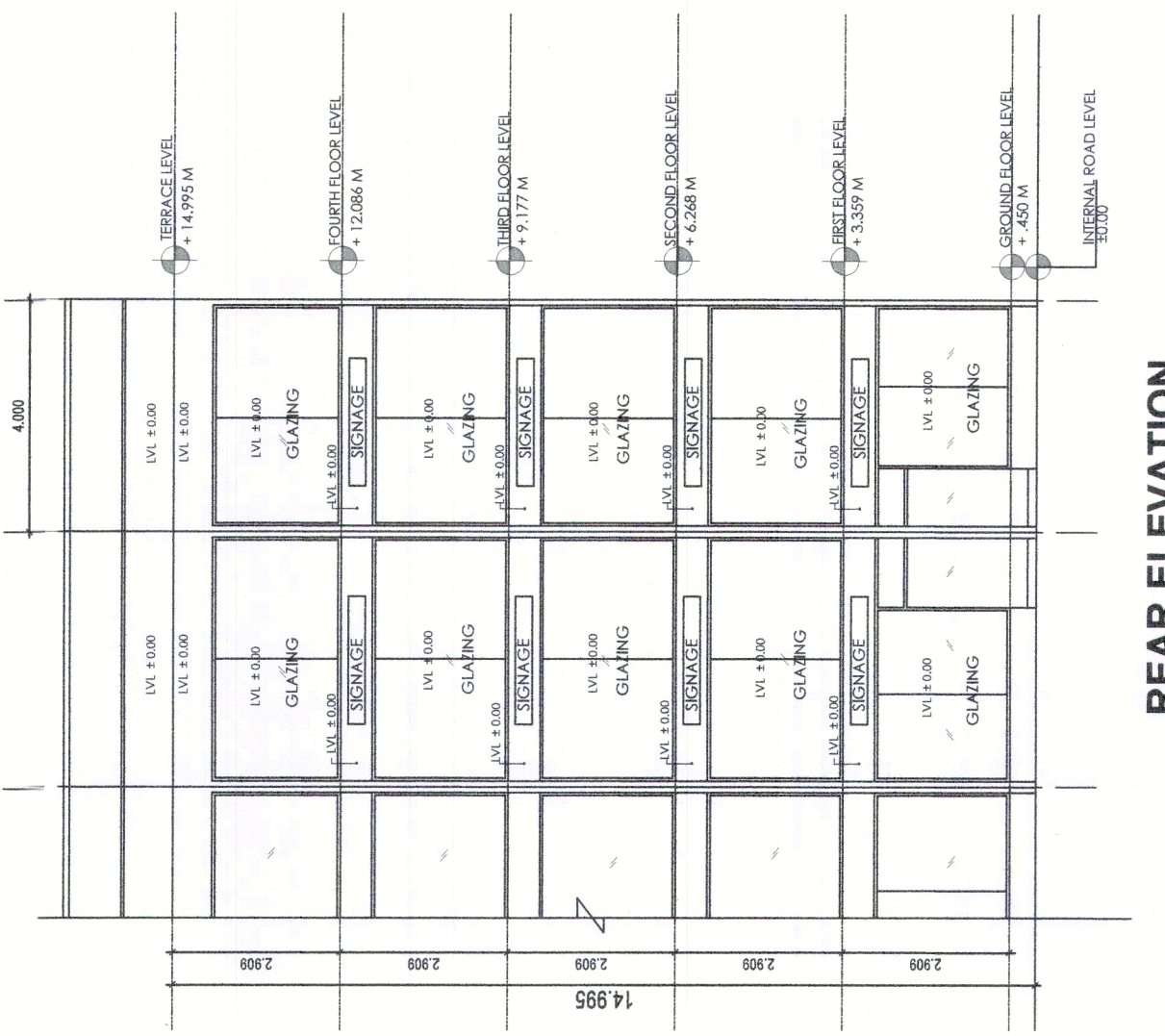
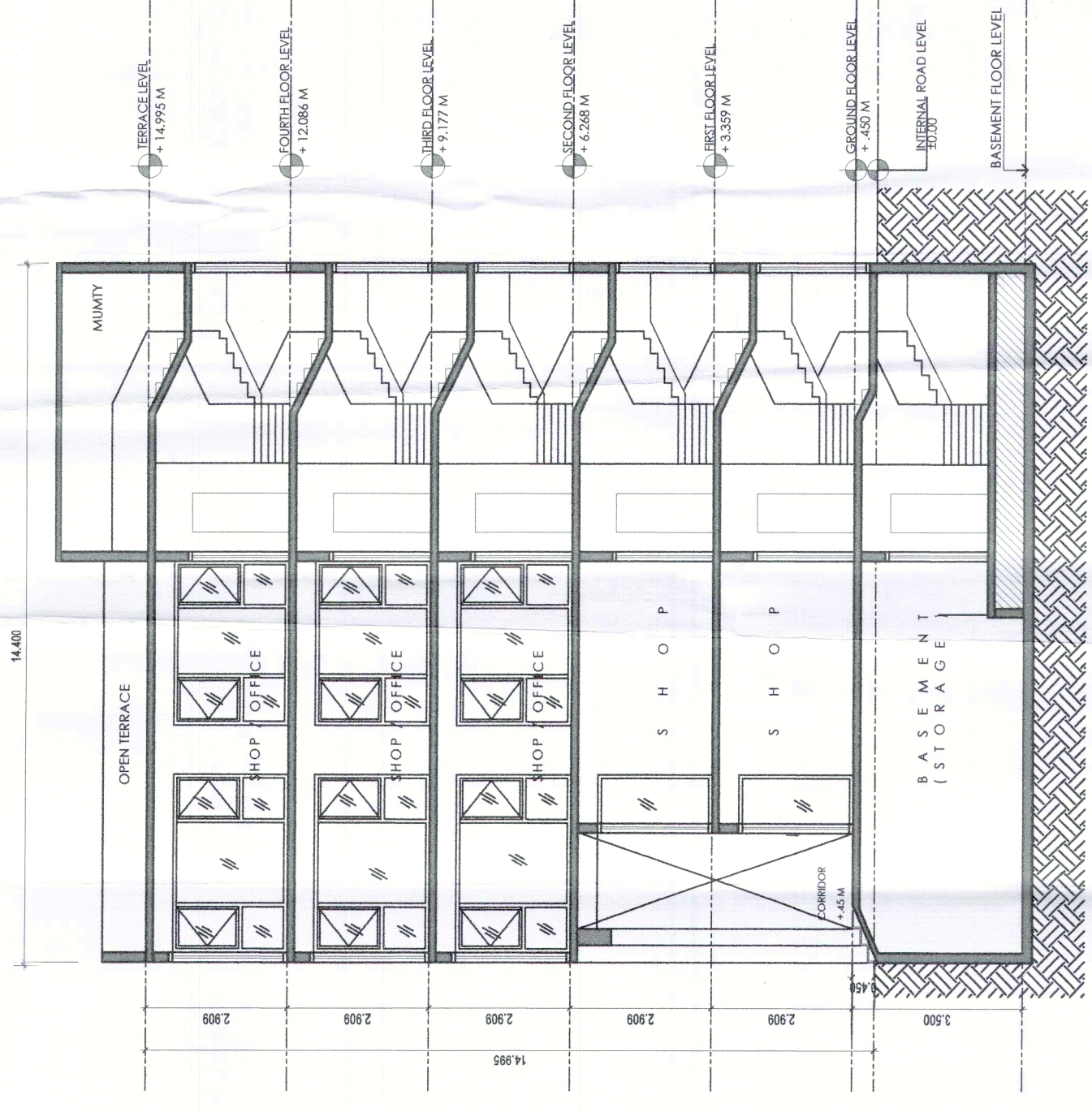

LONGITUDINAL SECTION (THROUGH STAIRCASE)

REAR ELEVATION

FRONT ELEVATION

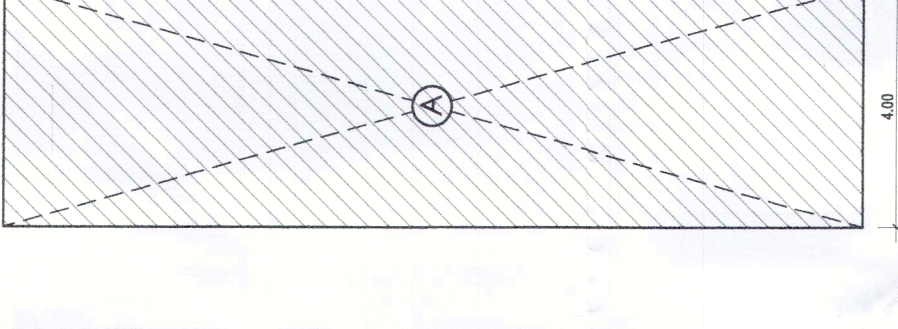
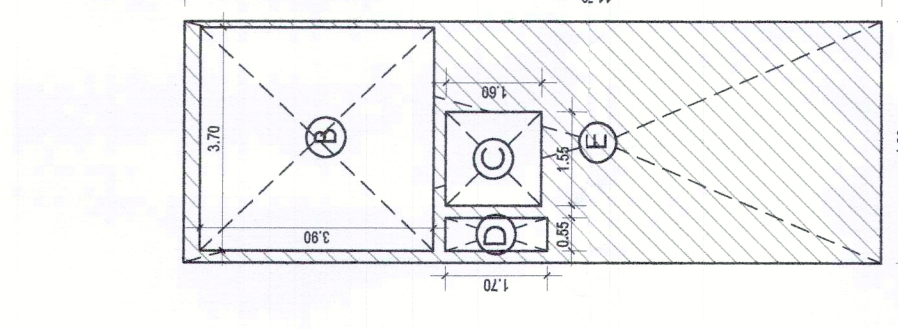
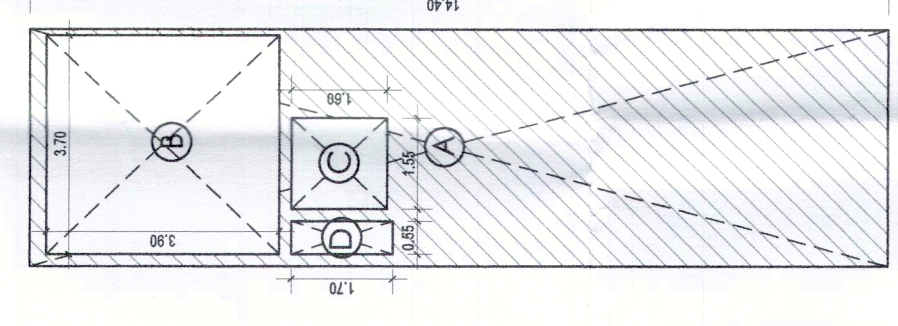
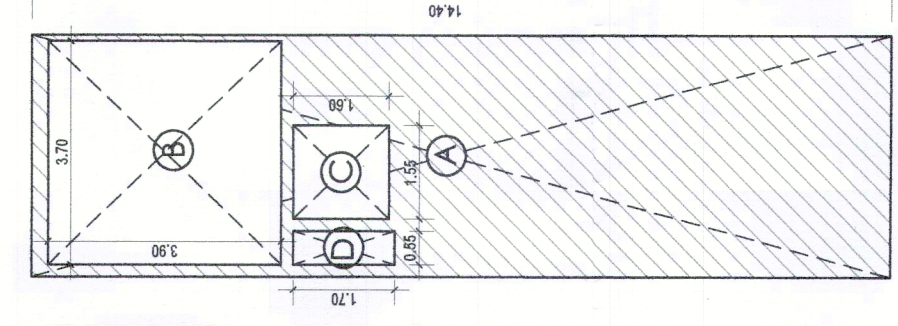
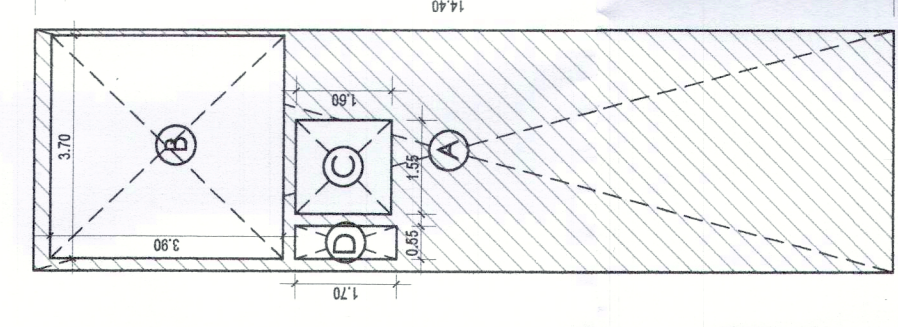
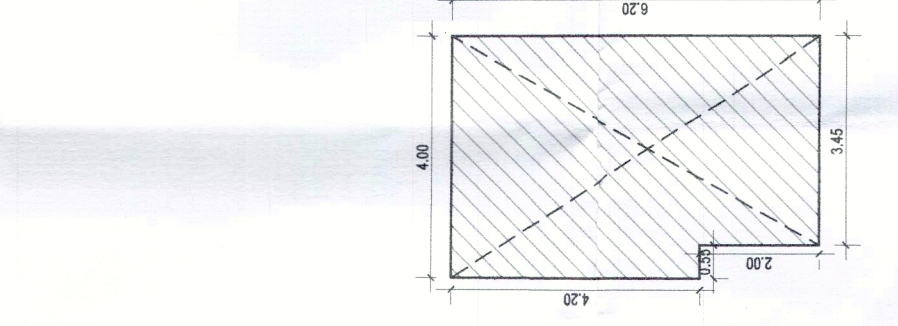

SCO TYPE D(01)

FLOOR	WIDTH (M)	DEPTH (M)	PLOT AREA (SQM)	DEDUCTION (LIFT, STAIRCASE, SHAFT) (SQM)	FAR AREA (SQM)	FAR AREA (SQ YRDS)
GROUND FLOOR	4.00	14.40	57.60		57.60	68.89
FIRST FLOOR	4.00	11.70	46.80	17.85	28.95	34.63
SECOND FLOOR	4.00	14.40	57.60	17.85	39.75	47.55
THIRD FLOOR	4.00	14.40	57.60	17.85	39.75	47.55
FOURTH FLOOR	4.00	14.40	57.60	17.85	39.75	47.55
FAR PER PLOT					205.82	246.16
TOTAL FAR OF THE PLOTS (1 NOS.)					205.82	246.16

MUMTY FLOOR AREA DIAGRAM

FOURTH FLOOR AREA DIAGRAM

THIRD FLOOR AREA DIAGRAM

SECOND FLOOR AREA DIAGRAM

FIRST FLOOR AREA DIAGRAM

GROUND FLOOR AREA DIAGRAM

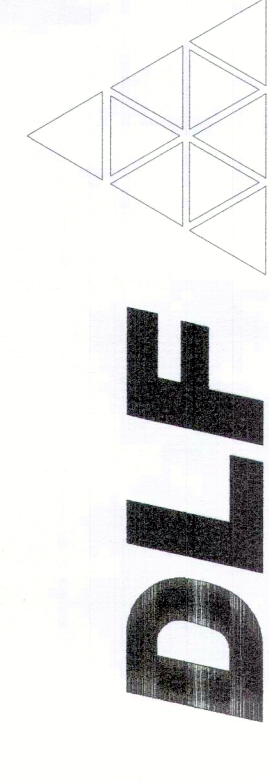

DLF HOME DEVELOPERS LTD.

PROJECT TITLE
SCO AT SECTOR 84, GURUGRAM

DATE	REVISION	DESCRIPTION

ARCHITECT:
ANIL KUMAR PATEL PVT. LTD.
A-15, Pampoh Enclave, G.K. 1
New Delhi-110048
Phone: 011-26402680

STRUCTURE CONSULTANTS:

MEP CONSULTANTS:

AUTHORIZED SIGNATORY:-
ARCHITECT'S SIGNATURE:-
(Signature)

SHEET TITLE
**SCO TYPE D (01)
PLAN, AREA DIAGRAM, ELEVATIONS**

Document Release Type
SUBMISSION DRAWING

Job No.	
Scale	1:125 ON A1 SHEET
Date	10 DEC, 2021
Drawn by	SD
Checked by	Jsk
DRAWING NUMBER	AR-84-TYPE D-01
Revision No.	

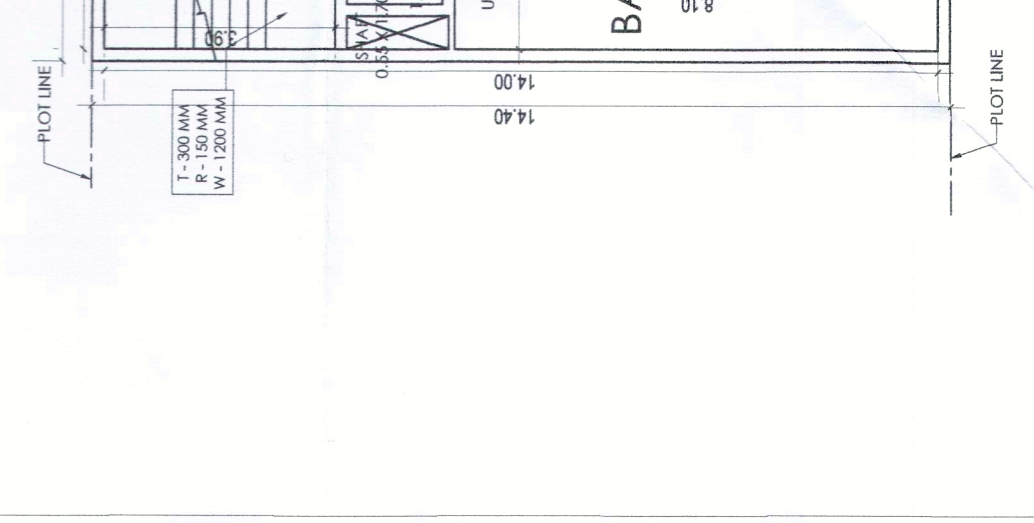
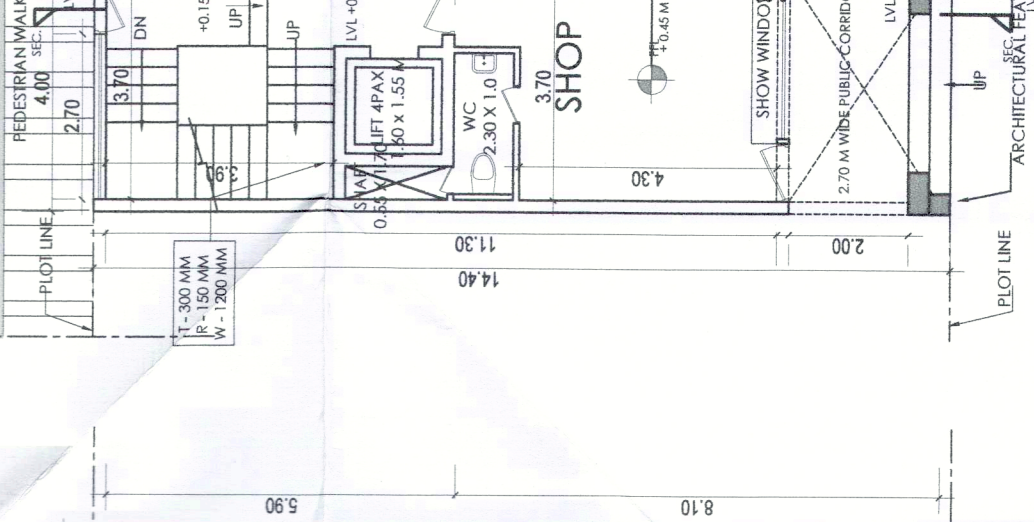
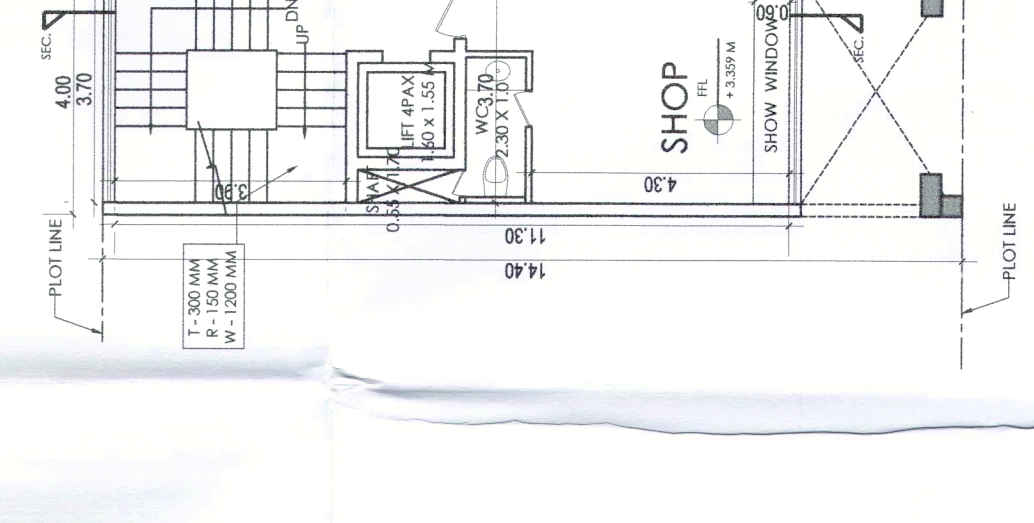
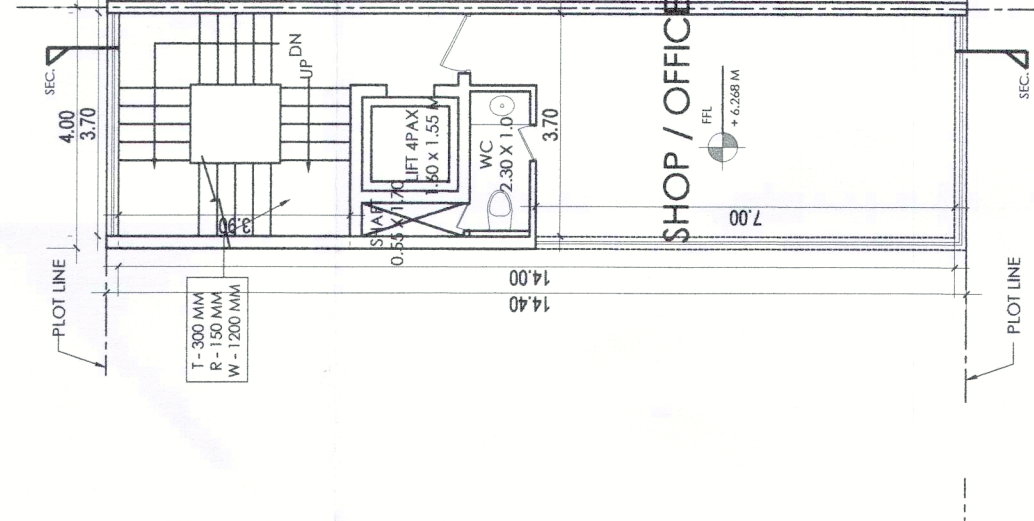
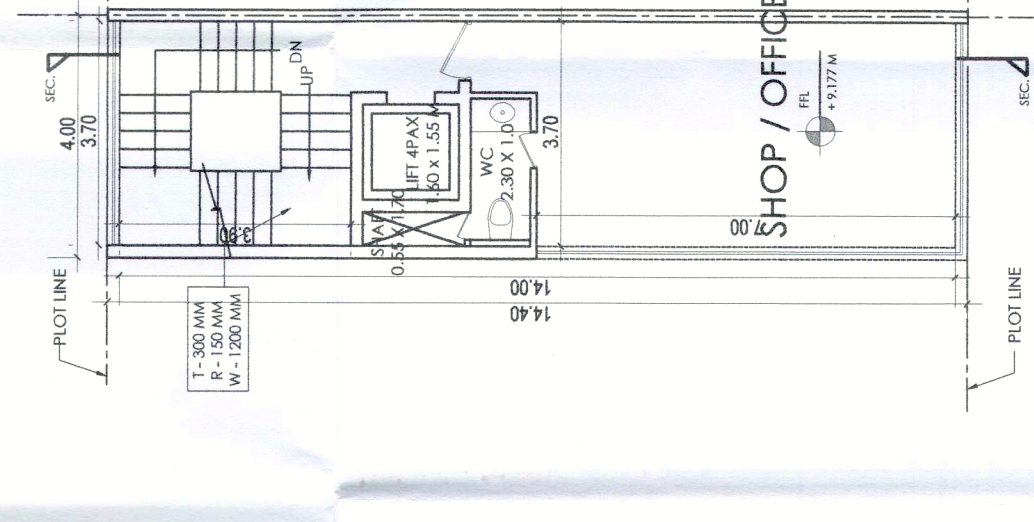
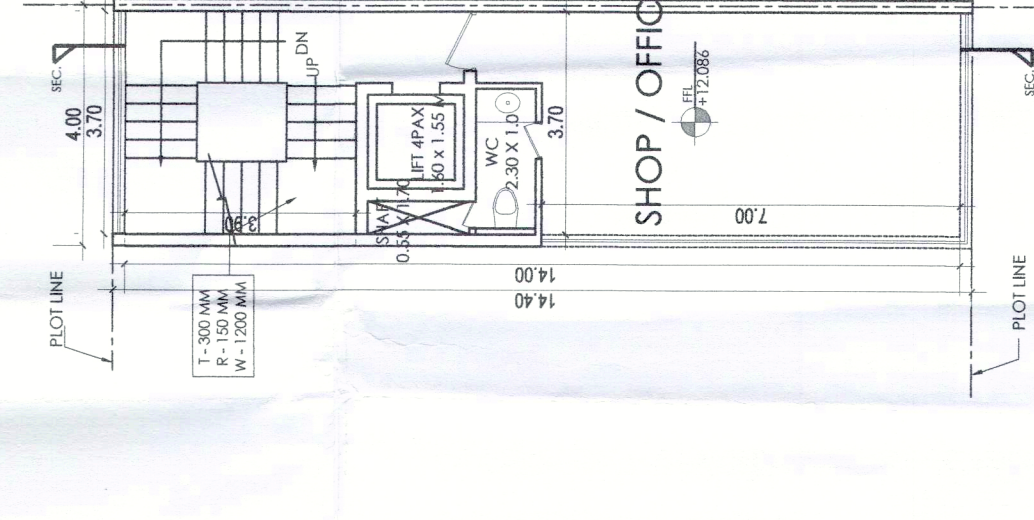
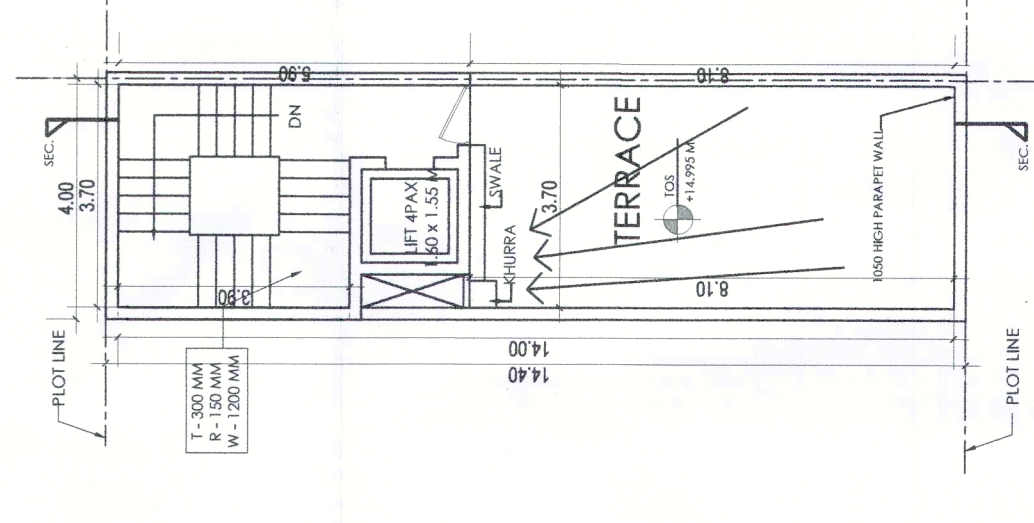

TERRACE FLOOR PLAN

FOURTH FLOOR PLAN

THIRD FLOOR PLAN

SECOND FLOOR PLAN

FIRST FLOOR PLAN

GROUND FLOOR PLAN

BASEMENT FLOOR PLAN

Dy. No DTC-8164-XIV DATED-21-02-2022

(HITESH SHARMA) STP (HQ) M

(HITESH SHARMA) ARCHITECT (HO)

(DINESH KUMAR) SD (HQ)

(K. MAKRAJ PANDURANG IAS) DTCP (HR)